

Sparkling water dispenser

User manual

Model: KS2201U-E3

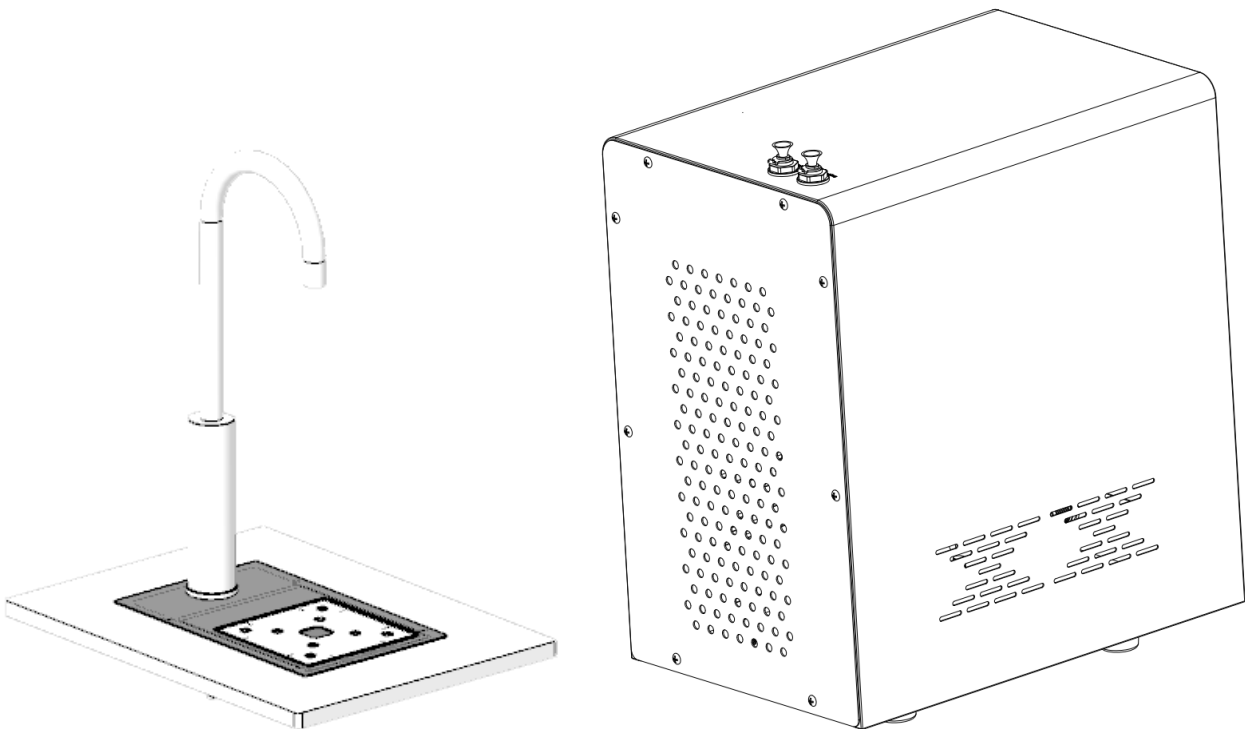

NOTICE: Thank you for purchasing our sparkling water cooler. Please thoroughly read this instruction to learn how to use the water cooler safely and appropriately. And please retain this instruction for future reference.

NOTE: This publication is based on information available at the time of approval for printing. Ongoing design improvements may result in changes not included in this publication.

Table of Contents

Safety Information.....	3
Component Guide.....	4
Package Contents.....	4
Materials needed.....	4
Operational Specifications.....	5
Technical Specifications.....	5
Installation.....	6
Operating the machine.....	10
Troubleshooting.....	11

Congratulations on choosing our product. We have carefully designed and manufactured this product to ensure it provides you with a great drinking experience. To get the most out of your water dispenser, please read the instructions in this manual and retain this manual for future reference.

Safety Information

WARNING: To reduce risk of injury and property damage, you must read this entire guide before assembling, installing and operating the dispenser. Failure to use properly can cause personal injury. When operating this dispenser, always exercise basic safety precautions, including the following:

- This appliance is intended to be used in home and similar applications. Place the appliance away from water jets, direct sunlight and heat sources.
- Keep ventilation openings, in the appliance enclosure or in the built-in structure, clear of obstruction, especially when installed under a counter, leave at least 4 inches (100 mm) of space around the unit.
- To protect against electric shock, do NOT immerse cord, plug, or any other part of the dispenser in water or other liquids. The dispenser must not be immersed.
- Do NOT use the dispenser if the power cord becomes frayed or otherwise damaged. If the power cord is damaged, it must be replaced by the manufacturer, its service agent, or similarly qualified persons in order to avoid a hazard.
- Do NOT use a shared socket. Dispenser requires a dedicated and properly grounded outlet.
- To provide additional protection from the risk of shock, the dispenser MUST be connected to a ground fault circuit interrupter (GFCI) outlet at all times. Use of an extension cord will void any warranties.

WARNING: The dispenser must be grounded – if the appliance is improperly grounded, it may result in an electric shock

- Install and use on a hard, flat, and level surface. Keep out of direct sunlight and away from heat sources.
- Do NOT clean dispenser with a water jet.
- Unplug power cord or disconnect power supply before performing any maintenance.
- Unplug the power cord and turn off water source if dispenser is not to be used for an extended period.
- This dispenser can be used by children aged 8 years and above and by people with reduced physical, sensory, or mental capabilities or lack of experience and knowledge, as long as they are under supervision or guidance on safe use of dispenser and understand the risks involved.
- No child should clean or maintain the dispenser without supervision.
- Do NOT use in environments where the ambient temperature is lower than 41 °F (5 °C) or higher than 107.6 °F (41 °C).
- To avoid a hazard due to instability of the appliance, it must be fixed in accordance with the instructions.

WARNING: Do not use mechanical devices or other means to accelerate the defrosting process, other than those recommended by the manufacturer.

- The following symbol indicates that the R600a refrigerant used in the machine is flammable.



WARNING: Designed for use with 220~240V AC power only. DO NOT use with 115V outlet.

Component Guide

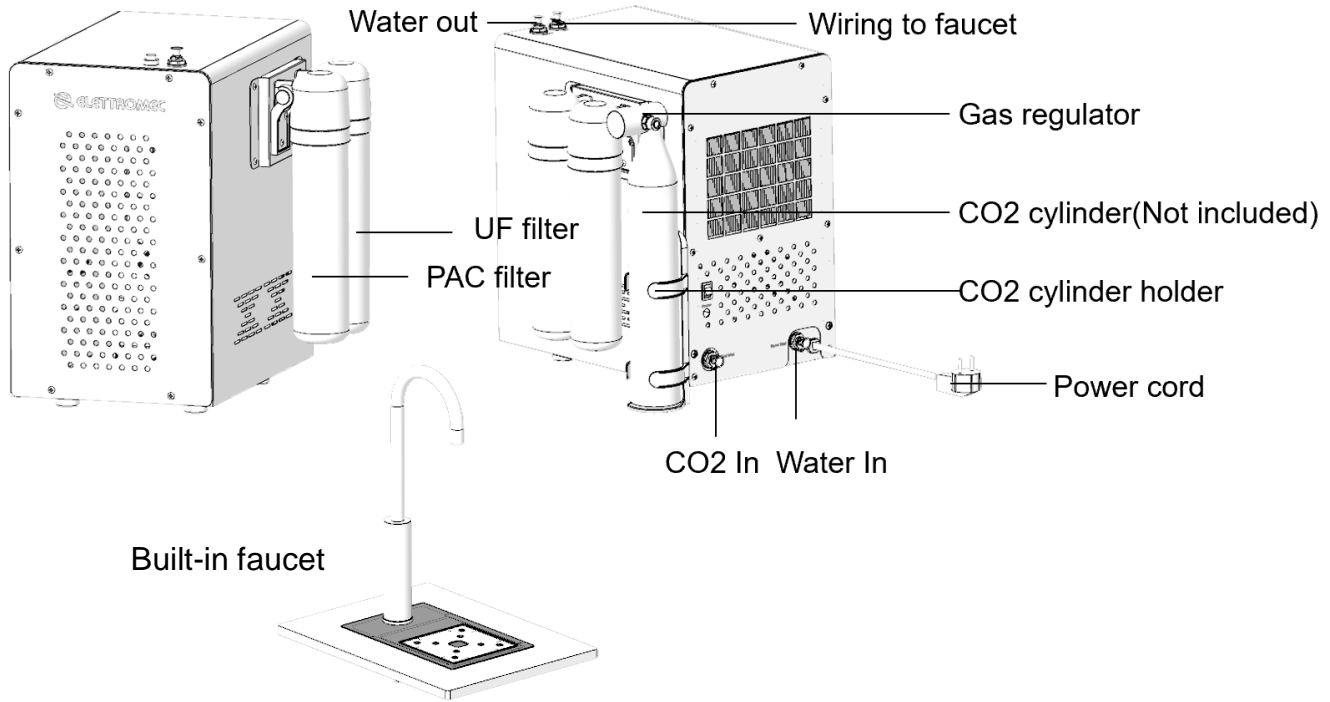

Package Contents

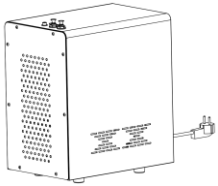

Machine ×1

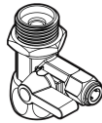

Feed water adapter ×1



CO2 regulator ×1



Filter PAC ×1
Filter UF ×1

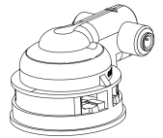

Flush filter housing ×1



Faucet ×1



CO2 cylinder holder ×1

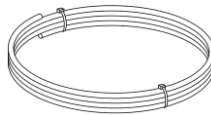

PE pipe ×1

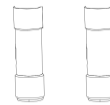

1/4" to 1/4" connector ×1
3/8" to 1/4" connector ×1

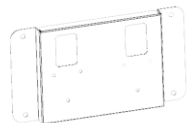

Filter bracket ×1

NOTE: Check if the machine and accessories are in good condition and complete. Contact the seller if you find any issues.

Materials Needed



Wrench ×1



Plumber's tape ×1



Tube cutter ×1



CO2 cylinder ×1

Operational Specifications

You must use the dispenser within the following operational parameters to ensure safe, optimal performance.

Model No.	KS2201U-E3
Rated Voltage / Frequency	220V / 60Hz
Rated current	0.44A
Rated cooling current	0.44A
Operating ambient temperature	5-41°C
Operating humidity	≤90%
Operating source water	Municipal water
Operating source water temperature	4-38°C
Inlet water pressure	0.1~0.3MPa
Inlet water pipe	Φ1/4"
Inlet gas pressure	0.4±0.03MPa
Inlet gas pipe	Φ1/4"
CO2 cylinder(Not included)	Universal 60L screw-in with thread M18×1.5 and TR21-4
Cylinder installation	External CO2 regulator
Faucet	Built-in SS304 electric faucet

Technical Specifications

Model No.	KS2201U-E3
Cold tank volume	4.5L(Incl. soda tank:1.0L)
Cooling capacity	9.0L/h(≤10°C)
Sparkling water carbonation level	3.0%
Cooling technology	Compressor
Condensation	Forced ventilation(fan)
Refrigerant	R600a, 20g
Net weight	18kg
Product dimension	52*34*48cm (excl. filters)
Noise (dBA)	≤49dB

Installation

Unpack the Kit

1. Remove the tapes on the package.
2. Lift up the machine and take it out.
3. Check the machine carefully for damage during transportation. Any signs of damage must be reported to the Agent immediately.
4. Ensure the power switches are in the OFF position.

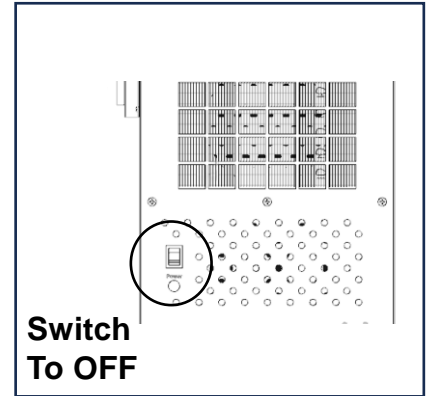

WARNING: The end user is not permitted to access the internal service parts of the unit. Only technical personnel can perform such operations.

WARNING: This appliance contains a compressor that requires it to be always kept upright. Unit may have been tilted or laid on its side during transport or handling. Please allow it to stand upright for at least 24 hours before plugging it in. This ensures proper functioning and longevity of the compressor.

WARNING: DO NOT plug in the power cord until the entire installation section is completed.

WARNING: When the machine is installed inside a cabinet, especially cabinet with a door, be sure to ensure that the cabinet has good ventilation and heat dissipation environment.

Materials Needed

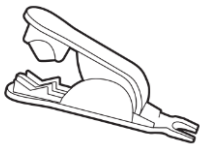

Tube cutter



Wrench



Plumber's tape



CO2 cylinder

Connect to Cold Water Supply

CAUTION: DO NOT CONNECT THIS WATER LINE TO A HOT WATER SUPPLY LINE. The water supply to the unit MUST be from the COLD WATER LINE. Using HOT WATER will severely damage your machine.

NOTE: You will need 2 pieces of PE tubing to flush filters. Ensure sufficient length to accommodate distance from feedwater adapter to filter, and from filter to sink or receptacle.

IMPORTANT: We recommend using plumber's tape on threaded connections to ensure a secure seal

1. Turn off cold water supply, then disconnect cold water pipe from cold water supply line.
2. Connect the feed water adapter to the cold water supply line.
3. Connect the cold water pipe to the top of the feedwater adapter.
4. Insert one end of cut PE tubing directly into feedwater adapter quick connect. Gently tug on tubing to ensure a secure connection

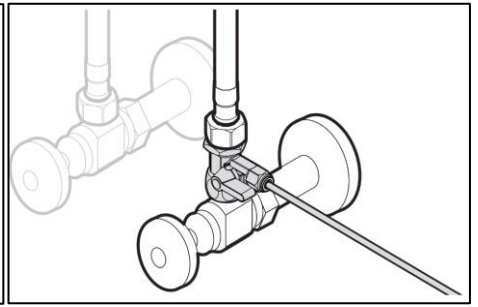
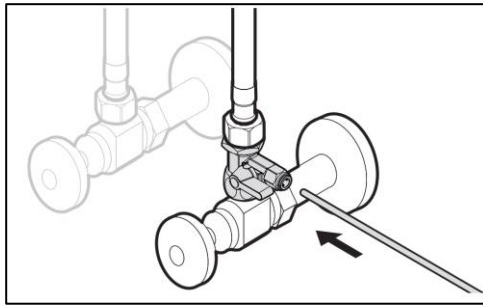
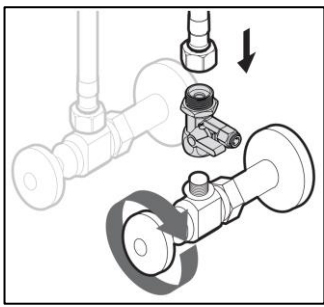

Flush the Filters

Follow this procedure every time you replace your filters.

IMPORTANT: Ensure the water supply is off before you begin.

1. Connect a filter to the filter housing by twisting the filter counterclockwise.
2. Connect the free end of the PE tube to the inlet side of the filter housing.
3. Connect the second piece of PE tubing to the outlet side of the filter housing and lay the open end of the filter flushing tube over a sink or receptacle to collect water.
4. Turn on water supply and flush each filter at least 5 minutes.

IMPORTANT: After each filter is flushed, be sure to shut off water supply before disconnecting tubes to flush the next filter.

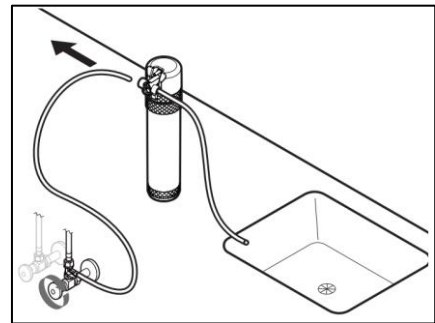
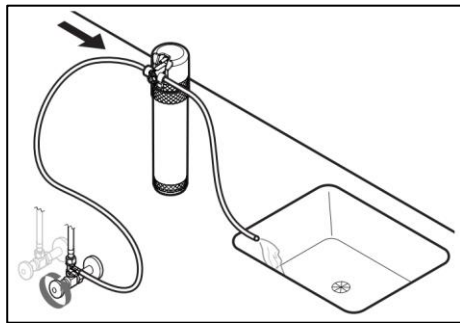
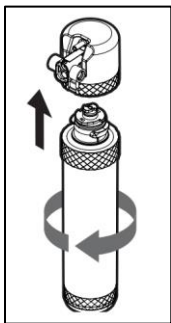

Install Filter Bracket and Filters

1. Install the filter bracket to the right side of machine with 4 screws.
2. Install the 2 filter housings to the filter bracket with 6 screws.
3. Install filters by rotating counterclockwise into corresponding filter housing. PAC filter goes on the left, and UF filter goes on the right.

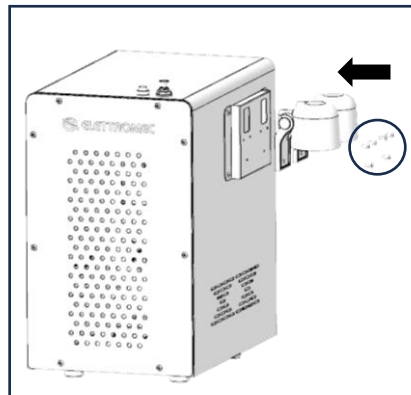
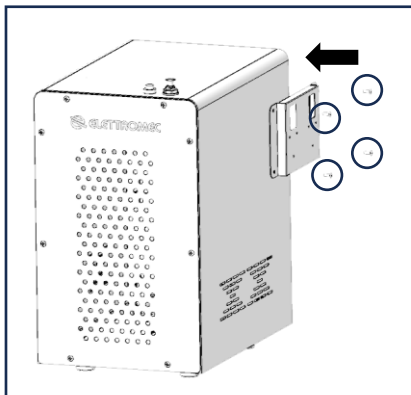

Remove Plugs

1. Remove the plug of the Water Out.
2. Remove the plug of the CO2 In and Water In.

Note: The plug is removed by pressing in ring of the joint and pulling on the plug simultaneously.

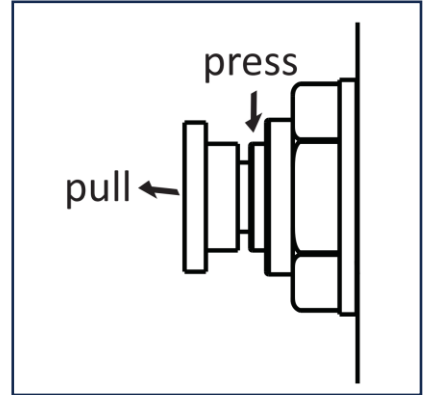
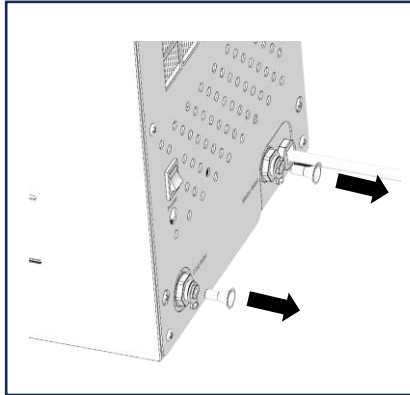
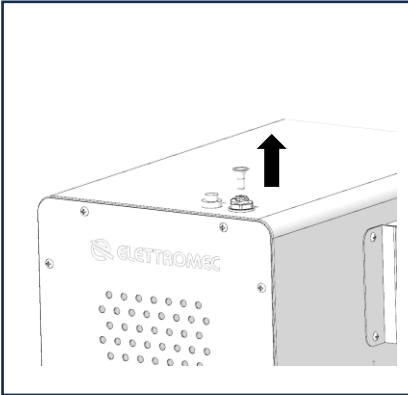

Install CO2 Cylinder

1. Cut a tube to the appropriate length. Insert the tube straight into the quick connection of the CO2 cylinder regulator ❶.
2. Insert the other end of tube into the CO2 In ❷ on the back of the machine.
3. Install a new CO cylinder ❸ to the CO2 cylinder regulator ❶ by rotating counterclockwise until it is securely attached and no sound of CO2 releasing can be heard.
4. Put the CO2 cylinder into the black cylinder holder ❹. There are magnets inside the cylinder holder. With that magnet, attach the CO2 cylinder to the side of the machine.

WARNING: The rear of the machine needs heat dissipation and the temperature is high. Do not place the CO2 cylinder at the back of the machine.

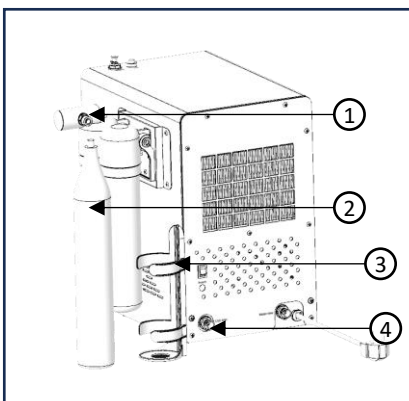

Install Faucet

1. Make a square hole on the tabletop where you want to install the faucet. The size of the square hole is 143.8mm*242.2mm while the front should be 143.8mm. Make two small semicircles on both sides of the square hole to facilitate the cylindrical bar to pass through.
2. Install the faucet ❶ to the drip tray panel ❷ securing tightly by base nut ❸.

- Put the drip tray panel ② on the square hole and secure the drip tray panel to the table by 2 metal bars ④ and 4 nuts ⑤.
- Put the drip tray cover onto the drip tray panel.
- Insert a 3/8"-to-1/4" quick joint ⑥ to the drain at the bottom of the drip tray. Cut a tube to the appropriate length. Insert the tube straight into the quick joint ⑥ and lay the open end of the tube to sewer or receptacle to collect water.
- Insert the tube ⑦ of the faucet to the Water Out ③ on top of the machine.
Note: if the tube is too short, use an 1/4"-to-1/4" quick joint and PE tube to extend the tubing to the machine.
- Connect the wiring from the faucet to the Wiring joint ⑨ on top of the machine.

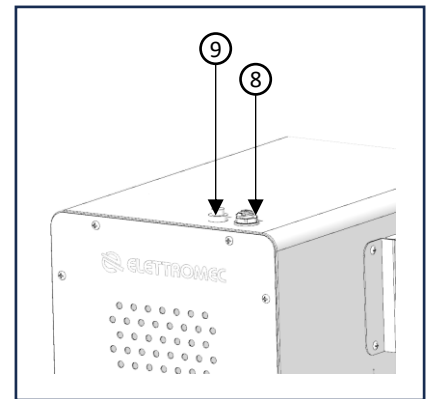
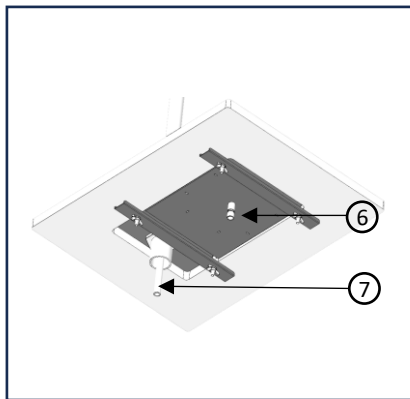
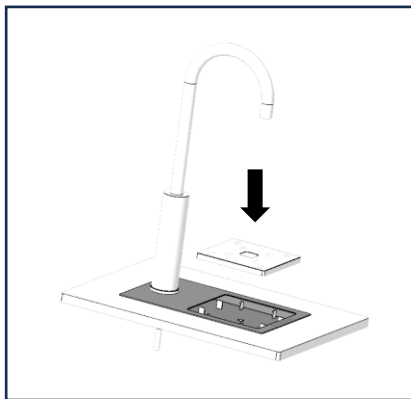
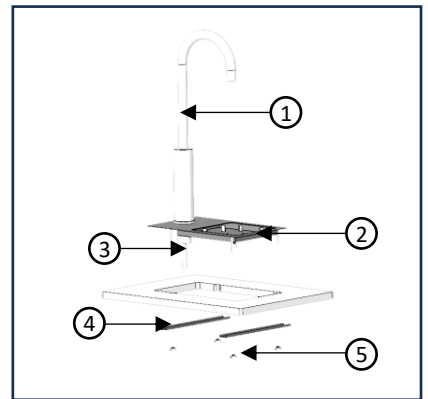
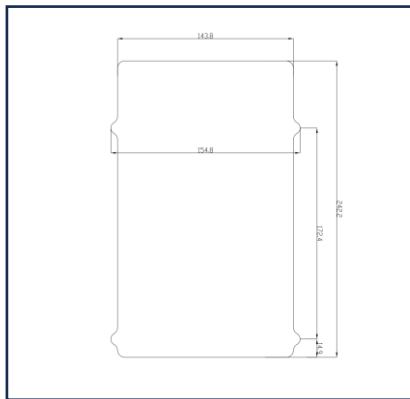
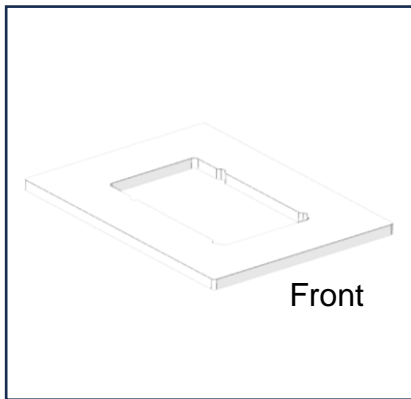

Connect to Water Supply and Supply Electricity

- Connect the tube ① from feedwater adapter to the inlet ② of first filter.
- Connect a tube from outlet ③ of the second filter to the Water In ④ at the back of the machine.
- Put all system back to the cabinet and turn on water supply.
- Plug in power cord and turn on the power switch at the back of the machine.

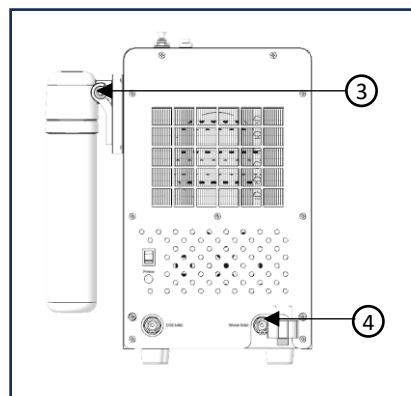
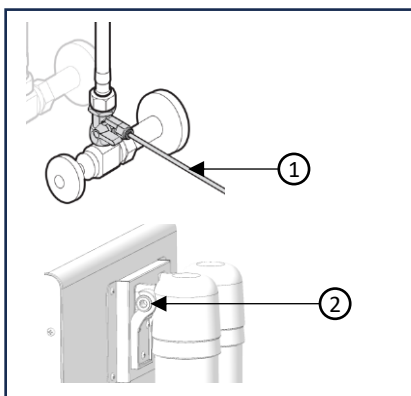

After installation, the first time cooling takes around 70-90 minutes. It's advise to dispense water after first time cooling finishes.

Operating the Machine

Dispense Cold Water

1. Place a container under the dispense point and press the cold water button to dispense.
2. Press the cold water button again when you've dispense the desired amount.

Dispense Room Temperature Water

1. Place a container under the dispense point and press the room temperature water button to dispense.
2. Press the room temperature water button again when you've dispense the desired amount.

Dispense Sparkling Water

1. Place a container under the dispense point and press the sparkling water button to dispense.
2. Press the sparkling water button again when you've dispense the desired amount.

NOTE: Sparkling water dispenses more loudly than the other water choices. This is caused the by the pressure required to push the water out. This is normal. Additionally, then you release the button, a short flush of water will come out due to pressure. This is normal.

Replace CO2 Cylinder

When the replace CO2 light illuminated in red, it's time to replace the CO2 cylinder. Replace the CO2 cylinder as soon as possible.

1. Take the CO2 cylinder out of the cylinder holder
2. Rotate the empty CO2 cylinder clockwise out from the CO2 cylinder regulator.
3. Dispose of properly.
4. Rotate a new CO2 cylinder counterclockwise into the CO2 cylinder regulator until there is a secure connection and no sound of CO2 releasing can be heard.
5. Put the new CO2 cylinder back to the cylinder holder and attach it back to the side of the machine.

Replace the Filters

When the replace filters light is illuminated in red, both filters have expired and need to be replaced.

1. Flush new filters according to "**Flush the Filters**" section.
2. One at a time, rotate expired filters upward 45°, then rotate clockwise to detach from filter housing.
3. Discard expired filters. Rotate new filters counterclockwise into filter housings until securely connected.

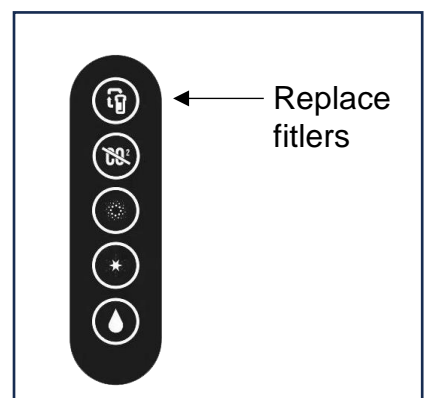
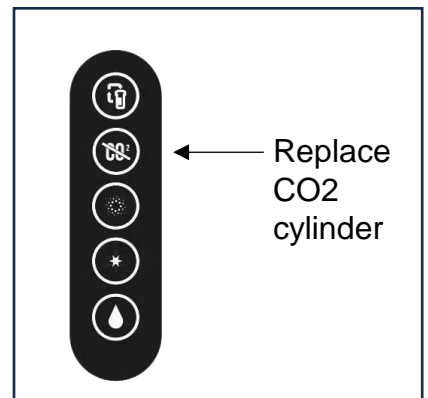
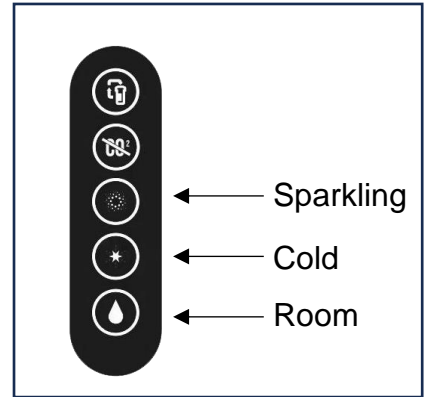

4. Press Reset button for 3 seconds. You'll hear 1 beeps in succession. The red replace filters light will go off. The filters are now reset.

Filter Function

Filter Name	Capacity	Function
PAC	6-9 months or 7200 liters	Remove oxide, residual chlorine, organics, mud, and sand
UF	6-9 months or 5400 liters	Remove bacteria, rust, colloid, organism

Troubleshooting

Problem	Possible causes	Solution
Cold water does not dispense.	<ul style="list-style-type: none"> A. Water source is not on. B. Cold tank is frozen 	<ul style="list-style-type: none"> A. Plumbed-in version: turn on water supply. B. Unplug dispenser and let sit for 6 hours to thaw
Cold water is not cold enough.	<ul style="list-style-type: none"> A. Too much cold water has been dispensed in a short amount of time. B. Cooling is not yet complete. C. Power supply or cooling switch is off. D. If water hasn't been dispensed in 4 hours, dispenser enters energy-saving mode. 	<ul style="list-style-type: none"> A. Allow cooling to finish. B. Ensure dispenser is connected to a working outlet and the cooling switch is ON C. Dispense either cold or sparkling water from dispenser and it will exit energy-saving mode. Then wait for cooling to complete.
Sparkling water does not dispense.	<ul style="list-style-type: none"> A. Cold tank is frozen. B. CO2 cylinder is not connected or it is empty. C. The pressure in the sparkling water tank is too high. D. Too much sparkling water has been dispensed in a short amount of time. 	<ul style="list-style-type: none"> A. Unplug dispenser and let sit for 6 hours to thaw B. Replace CO2 cylinder. C. Optionally, remove CO2 cylinder and dispense 10 oz. of sparkling water. After the booster pump stops pumping water, reinstall the CO2 cylinder. D. Wait for pump to refill sparkling water Tank

If none of the above methods can solve the problem, please contact after-sales service immediately for technical support.